

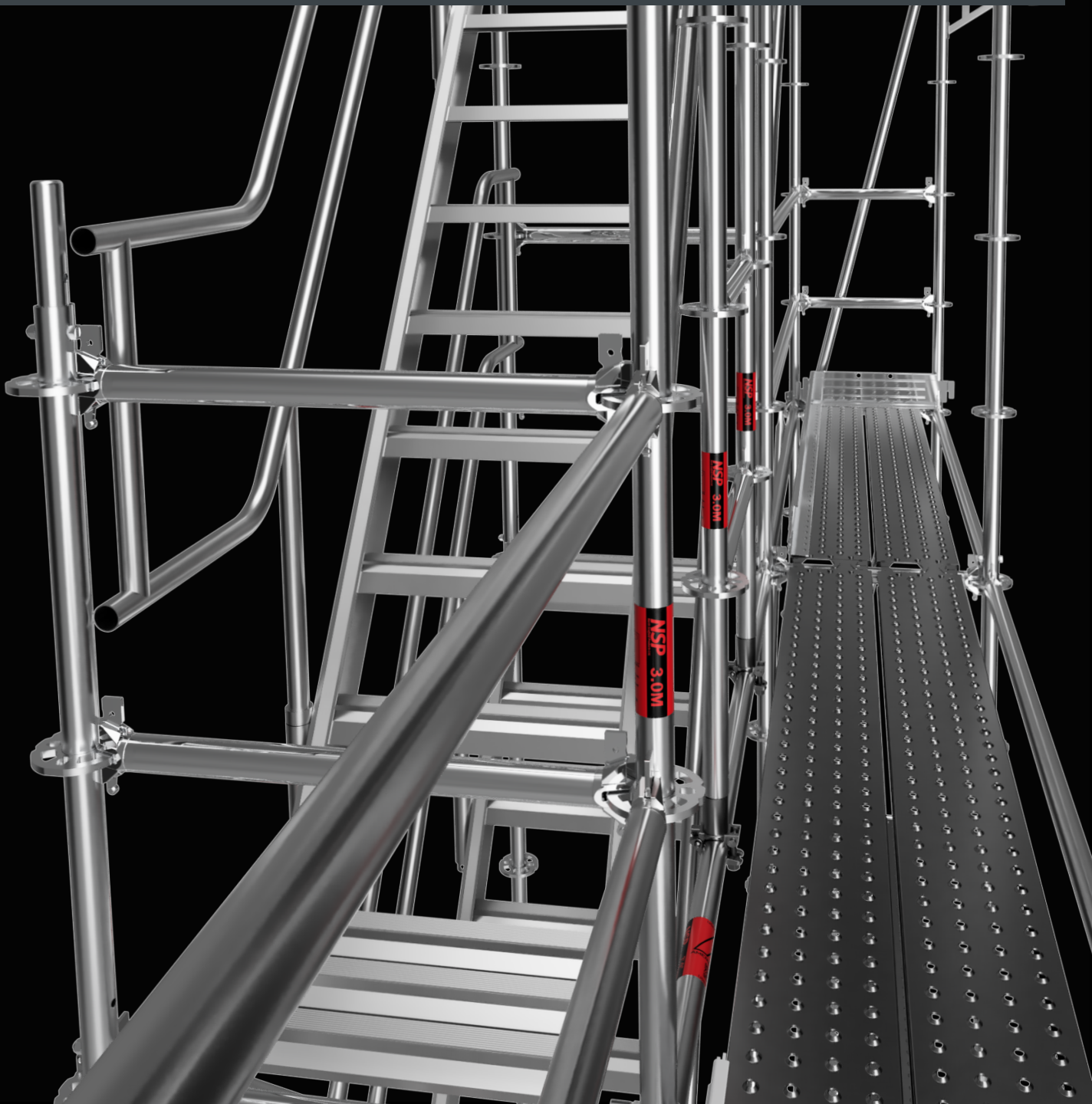

**NSP**  
North Scaffold Products Ltd.



## NSP RING SYSTEM SCAFFOLD

*Refined to exceed your expectations*

Elevate your scaffolding experience with NSP's Ring System, where innovation meets tradition, delivering superior performance and ease of use.

After identifying a common source of confusion in the industry, NSP has organized the Ring System product catalogue into two product categories, the American Product Line & the Euro Product Line. Both product lines have been meticulously designed to meet and exceed the best products on the market today.



## THE AMERICAN LINE

Designed to cater to North American markets' imperial measurements. These components seamlessly integrate with the sizing standards of major scaffolding distributors across the continent.

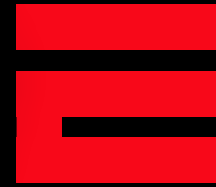

## THE EURO LINE

Designed to cater to international markets and the metric sizing systems commonly employed worldwide. These components seamlessly integrate with metric sizing standards, accommodating the diverse needs of scaffolding distributors and professionals across the globe.

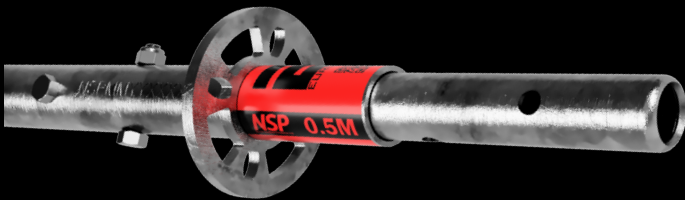

## EURO-PRO STANDARD

Engineered for higher loads and ideal for formwork shoring applications. Euro-Pro Standards are designed with quality grade steel and strict tolerances to allow for heavy duty use.

## EURO-PRO BASE COLLAR

Euro-Pro Base Collars are designed to be used in conjunction with the Euro-Pro Standard, crafted with quality grade steel and strict tolerances to allow for heavy duty use.

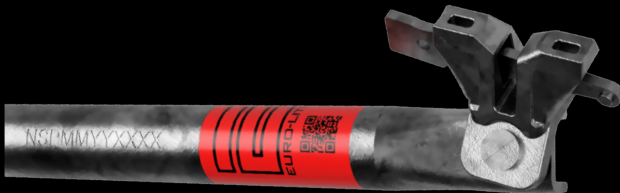

## EURO-LITE BAY BRACE

The Euro-Lite Bay Brace presents a cutting-edge solution, meticulously engineered with reduced wall thickness, resulting in a lighter product that's easier to ship and handle. Also available in American-Lite.

## AMERICAN-LITE LEDGER

Crafted with meticulous precision and featuring NSP's GravityLock wedge function, the American-Lite Ledger offers a lighter alternative to traditional ledgers without compromising its load bearing capabilities and security.

Also available in Euro-Lite.

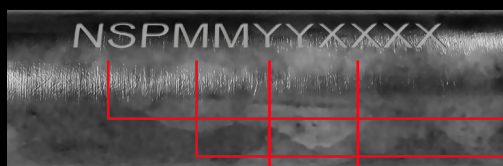

## PRODUCT TRACEABILITY

All NSP Ring components are stamped with traceability codes.

**NSP:** North Scaffold Products

**MM:** Month of Manufacture

**YY:** Year of Manufacture

**XXXX:** Reference Number

# DIAMOND BEAM™ ROOF SYSTEM

**Our cutting-edge roof system is specifically designed to offer unparalleled climate protection for a wide range of applications.**

Our innovative solutions incorporate high-strength Keder Tarps that effortlessly pull into place through guided Keder Tracks, ensuring a secure and reliable roofing structure. Whether you require temporary roofing for construction projects, outdoor events, industrial applications, or emergency shelter, our Aluminum Diamond Beam™ Roof System is the perfect choice.

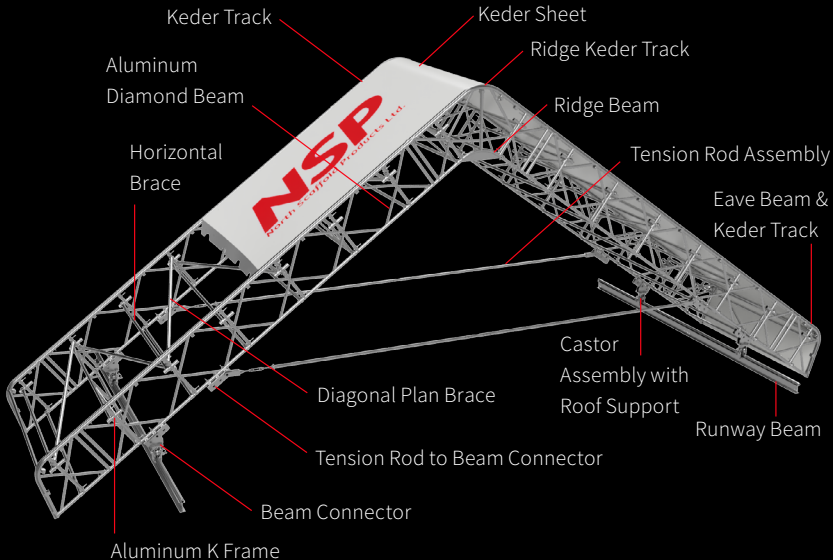

## INNOVATIVE CLIMATE PROTECTION

**When it comes to temporary roofing systems, NSP's Aluminum Diamond Beam Roof System sets the standard for reliability, versatility, and ease of use.** Experience the difference of our high-strength keder tarps and advanced engineering, and rest easy knowing that your climate protection needs are in capable hands.

*This image shows a difficult job in Vancouver's beautiful downtown core of a church renovation. A unique location requiring climate protection over a large span at difficult heights, no easy feat!*



*This image shows the roof structure that protected Brock Hall at the University of British Columbia (UBC) during its renovation phase. The scaffold provided a secure and accessible platform for workers, while the roof ensured the site was protected from adverse weather throughout the duration of the project.*

**Climate protection is at the forefront of our design philosophy.** Our Roof System is engineered to withstand a variety of heavy weather conditions, including heavy rain, strong winds, and even large snow loads. The high-quality keder tarps used in our system offer superior waterproofing and UV resistance, ensuring that your valuable assets and personnel stay protected in any climate.

*Here you can see a project supplied by NSP for a dormitory site to have additional climate protection from extreme snow loads. A perfect job for some heavy duty equipment and durable Keder Sheeting.*



## ULTRA-DECK (PLYWOOD)

*The strongest on the market*



Unmatched strength, durability, and equipped with a slip-resistant surface. Supports heavy loads, weather-resistant, and complies with all relevant safety standards. Elevate your construction projects with confidence and efficiency.

## ULTRA-LITE DECK (CFRT)

*The lightest on the market*

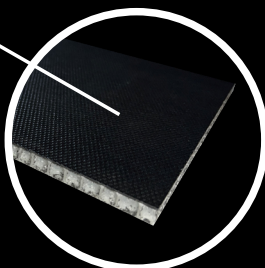

A CFRT (Continuous Fiber Reinforced Thermoplastic) scaffold deck is a game-changing solution for the scaffold industry. With its lightweight design and superior strength, it revolutionizes scaffolding applications.

STANDARD AND CUSTOM SIZES AND LENGTHS



## NSP N-PLANK

*The most versatile on the market*

Versatile and strong laminated veneer lumber adhering to CSA, ANSI, & OSHA guidelines. Custom sizes available for safe use in diverse applications, ensuring efficient and reliable construction.



## STEEL PLANK CORNER ASSEMBLY

*To fill the gaps in hard to reach areas*

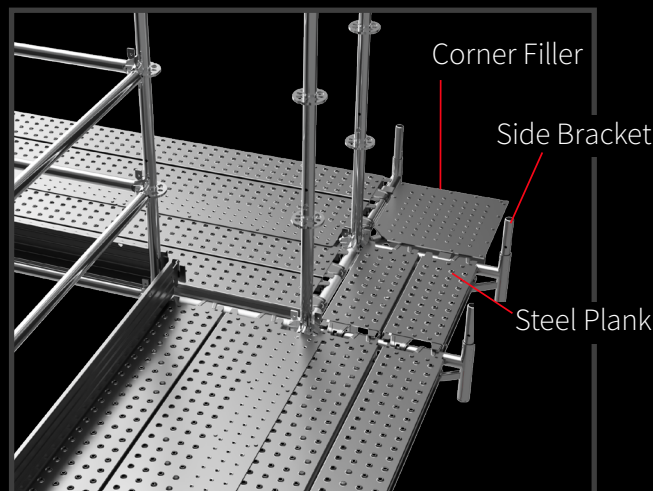
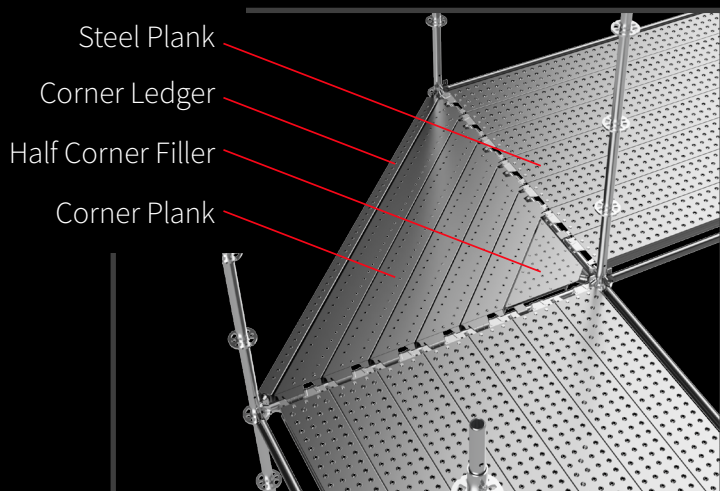

# NSP SCAFFOLD FRAMES

*The simplest on the market*

The Frame System is ideal for small to medium sized access/construction jobs. Rolling towers, like the one seen to the left, are incredibly versatile access structures and are great for any job on even surfaces. NSP Frames come in various styles and sizes, equipped with an extra lock for custom arrangements.

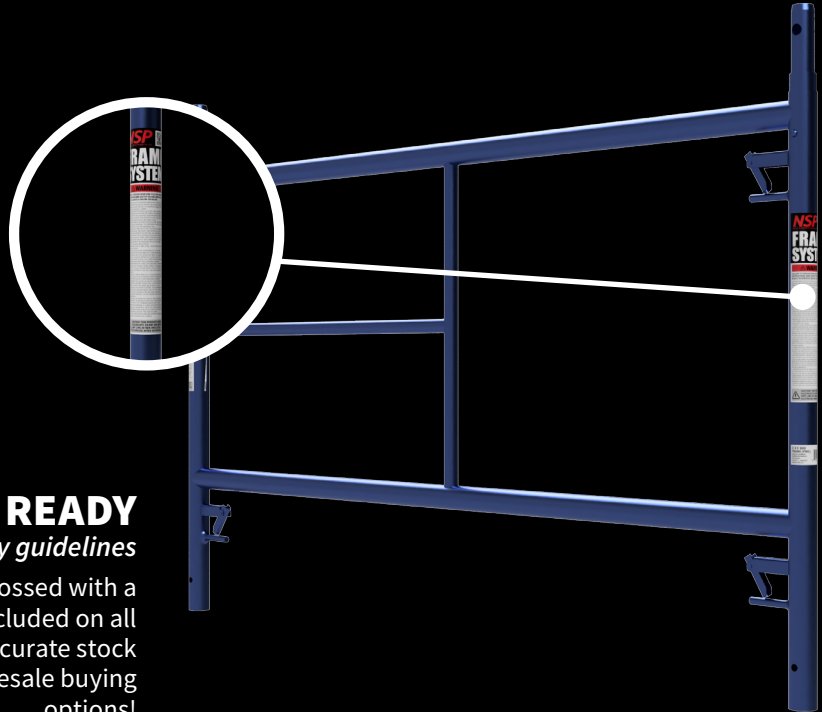

## RETAIL READY

*Traceability & safety guidelines*

The NSP Frame, like all NSP products, is embossed with a traceability code. Safety & usage guidelines are included on all NSP Frame Stickers. Barcode for retail use and accurate stock keeping. Contact us today to learn about our wholesale buying options!

## EXPLORE OUR NEW WEBSITE

[WWW.NORTHSCAFFOLD.COM](http://WWW.NORTHSCAFFOLD.COM)

Shopping cart feature for customers to browse items, build quotes, and access bulk pricing discounts!

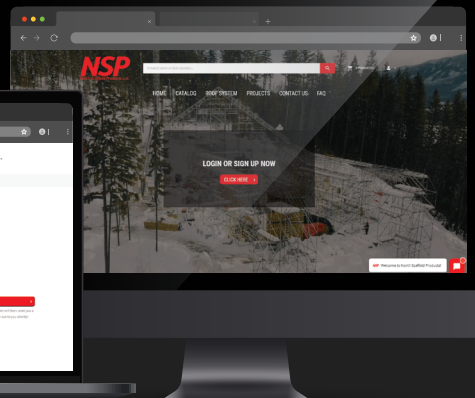
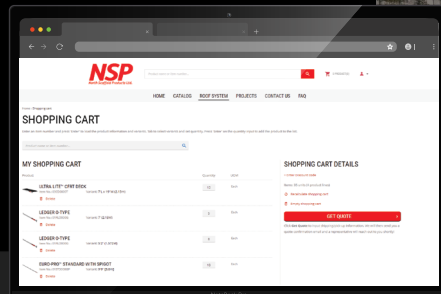

Mobile & tablet compatible for browsing on the go!

New product releases featuring the latest technology on the market. Stay tuned!

SCAN ME!





## EQUIPMENT SALES

Quality products sold online or at one of our store locations! See our location info below to find a store near you.



## ENGINEERING SOLUTIONS

In-house testing, quality control, and site engineering services allows NSP to give our customers everything they need for a project.



## EQUIPMENT RENTALS

NSP Products are also available for rental, and some orders can qualify for the rent to buy program.



## EXPRESS SHIPPING

NSP ships products to you anywhere, anytime. Reach out to us to learn more! In store pickup available upon request.

## CONTACT

**Toll Free:** 1-844-328-2113

**Email:** [info@northscaffold.com](mailto:info@northscaffold.com)

### Head Office (Vancouver)

North Scaffold Products Ltd.  
11531 134 Street  
Surrey, BC V3R 0H5

### Duncan, BC

North Scaffold Products Ltd.  
3015 Boys Road  
Duncan, BC V9L 6W4

### Campbell River, BC

North Scaffold Products Ltd.  
1390 Homewood Road  
Campbell River, BC V9W 6Y5

### Olds, AB

North Scaffold Products Ltd.  
5839 49 Avenue  
Olds, AB T4H 1G5

**NSP**  
North Scaffold Products Ltd.

## NOT JUST YOUR AVERAGE SCAFFOLDING COMPANY.

*North Scaffold Products Ltd. was established to manufacture and provide world class quality scaffold products with interchangeable parts.*

We designed our company to be a one-stop shop for all scaffold sales, rentals, express shipping, and engineering solutions across Canada and the US. With a commitment to excellence and customer satisfaction, NSP is your trusted partner for all your scaffold needs. All of our products are customizable to meet any site conditions. Contact us today to experience our top-quality products, efficient services, and innovative solutions.