

### Ø38mm Screwjack Hollow

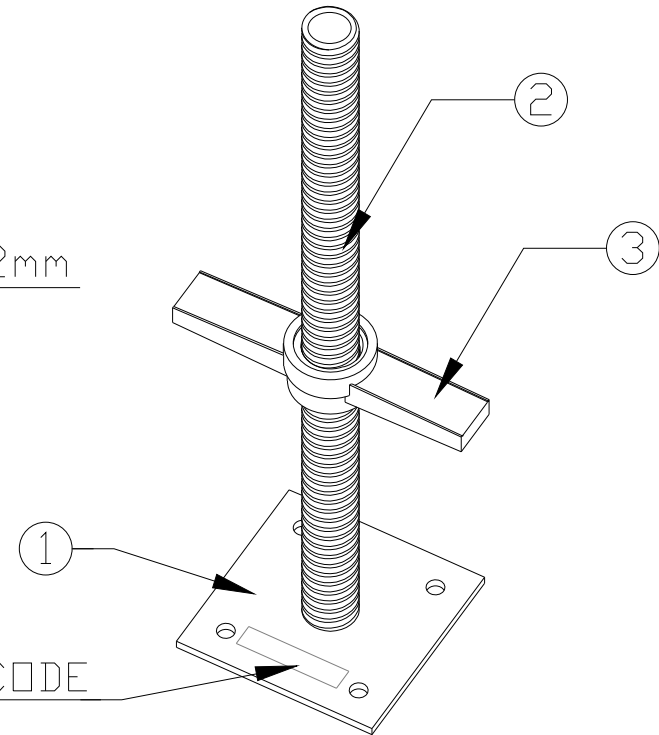
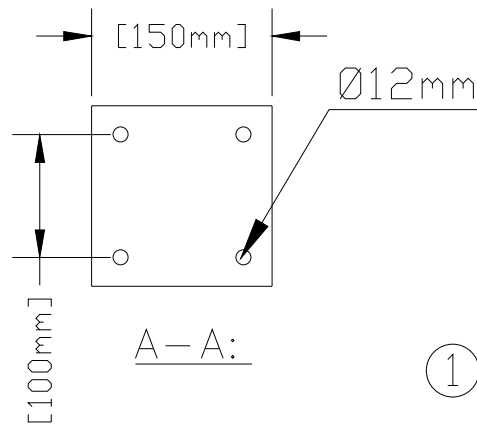
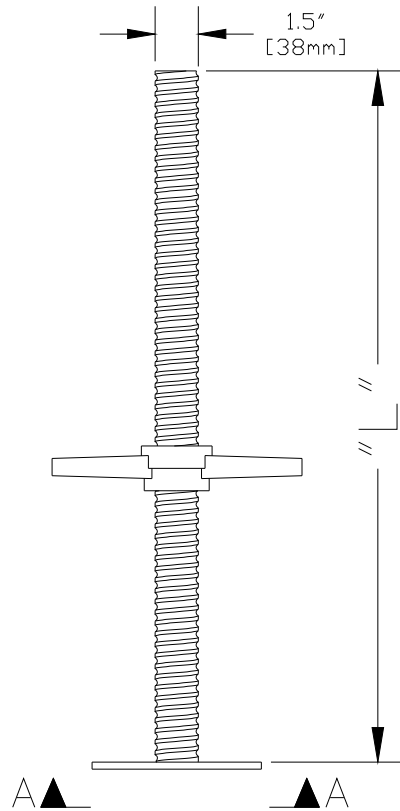

TRACEABILITY CODE

Ø38MM SCREWJACK HOLLOW DIAGRAM

**NOTES:**

1. THE STATE OF THE SCREWJACK DETERMINES WHETHER OR NOT THE THREADED SHAFT IS SOLID OR HOLLOW
2. ALL ALT. UNITS ARE MILLIMETERS

TRACEABILITY CODE:

NSPMMYYXXX

REFERENCE NUMBER

YEAR CODE

MONTH CODE

NORTH SCAFFOLD PRODUCTS LTD.

ITEM NO.	LENGTH "L"	WEIGHT	STATE	COMPONENTS	
01SJH024E	2'-0" [609.6]	4.0kgs / 8.8lbs	HOLLOW	S.NO.	DESCRIPTION
01SJH030E	2'-6" [762.0]	4.7kgs / 10.3lbs	HOLLOW	1	BASE PLATE
				2	THREADED SHAFT
				3	SWIVEL