

Guardpost

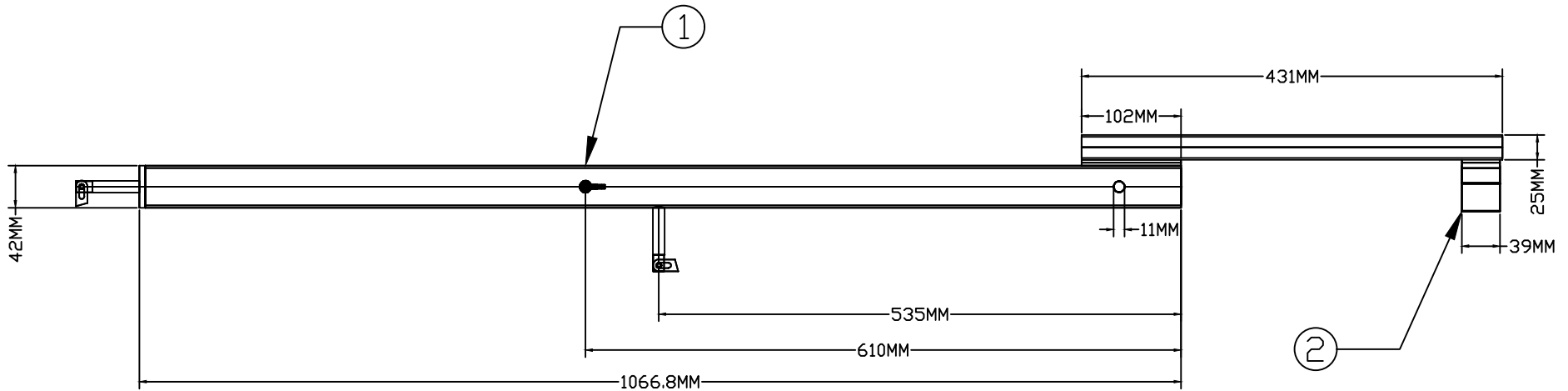

GUARDPOST DIAGRAM

NOTES:

1. COATING IS PWC (POWDER COATED)
2. INTENDED TO BE USED WITH THE NORTH FRAME SYSTEM & ACCESSORIES

ITEM NO.	PRODUCT NAME	WEIGHT	COMPONENTS	
02GDPS42P	42" GUARDPOST (PWC)	3.77 kgs	S.NO.	DESCRIPTION
02GDPS42G	42" GUARDPOST (HDG)	3.77 kgs	1	POST
			2	CLAW