

Stair Stringer & Tread

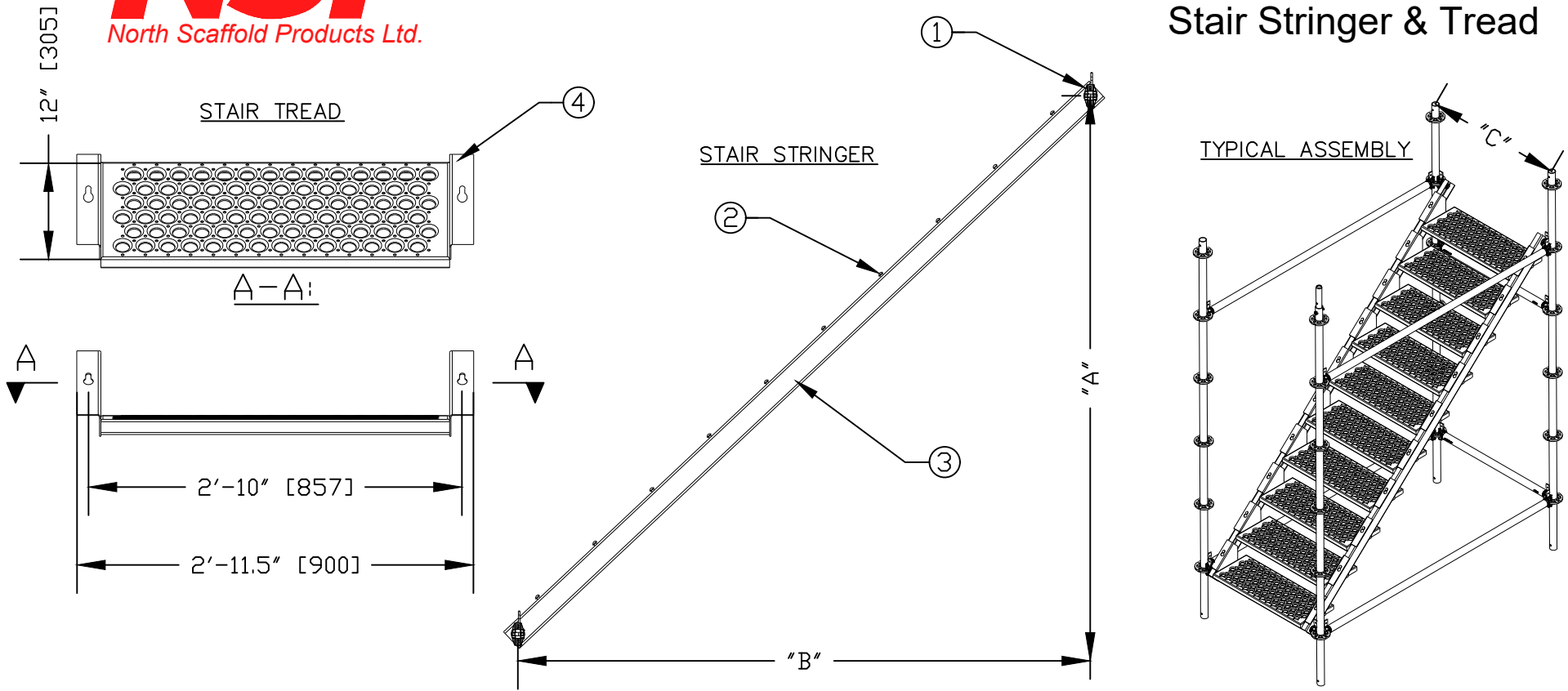

STAIR STRINGER & STAIR TREAD DIAGRAM

NOTES:

1. 10 STAIR TREADS PER 2x2m STAIR STRINGERS, 5 TREADS PER 2x1m STAIR STRINGERS
2. TREAD DEPTH = 12" [305MM]
3. STAIR RISE/RUN = 7.9"/8.4"
4. GRATED STAIR TREADS PREVENT SLIPPING.
5. TREAD
6. ALL ALT. UNITS ARE MILLIMETERS

ITEM NO.	PRODUCT NAME	"A"	"B"	"C"	LENGTH	WEIGHT	COMPONENTS	
01RSS200G	STRINGER 6'-6"	2.0m	7'-0"	3'-6"	9'-7"	16.1kgs/35.49lbs	S.NO.	DESCRIPTION
01RSS100G	STRINGER 3'-3"	1.0m	3'-6"	3'-6"	4'-10"	9.0kgs/19.84lbs	1	LEDGER HEAD
01RST032G	TREAD	-	-	-	2'-11.5"	8.2kgs/18.08lbs	2	TREAD RIVETS
							3	CHANNEL
							4	STAIR TREAD