

Transom Adaptor

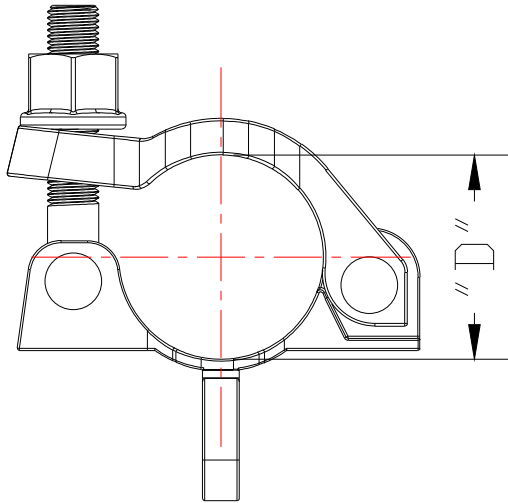

FRONT PROFILE

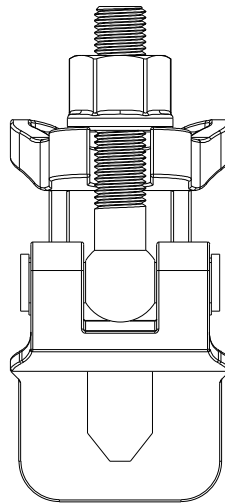

SIDE PROFILE

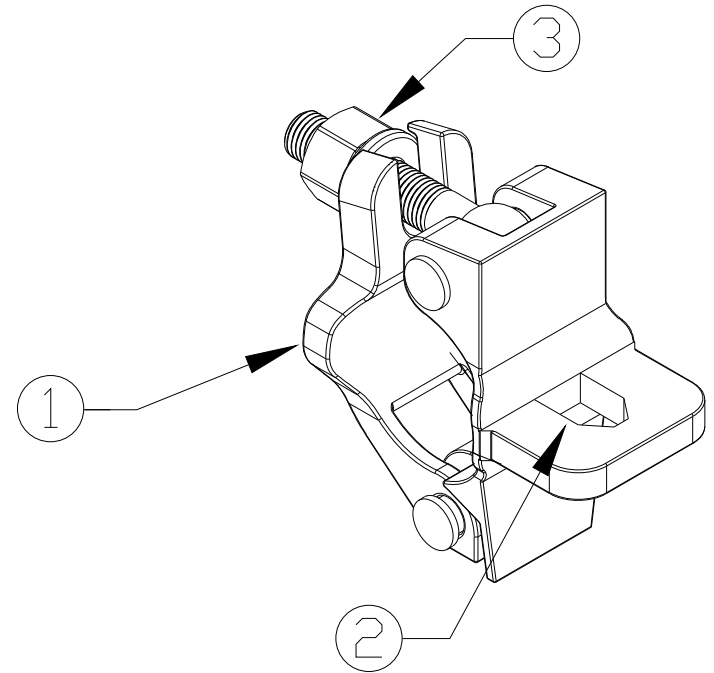

TRANSOM ADAPTOR DIAGRAM

NOTES:

1. TRANSOM ADAPTORS ARE FOR TUBE TO LEDGER HEAD CONNECTIONS
2. ALL ALT. UNITS ARE MILLIMETERS

ITEM NO.	DIAMETER "D"	WEIGHT	COMPONENTS	
			S.NO.	DESCRIPTION
01TAD000G	Ø48.3mm	0.8kgs/1.7lbs	1	CLAMP
			2	LEDGER CONNECTION
			3	I-BOLT & NUT