

Ultra Lite™ CFRT Deck

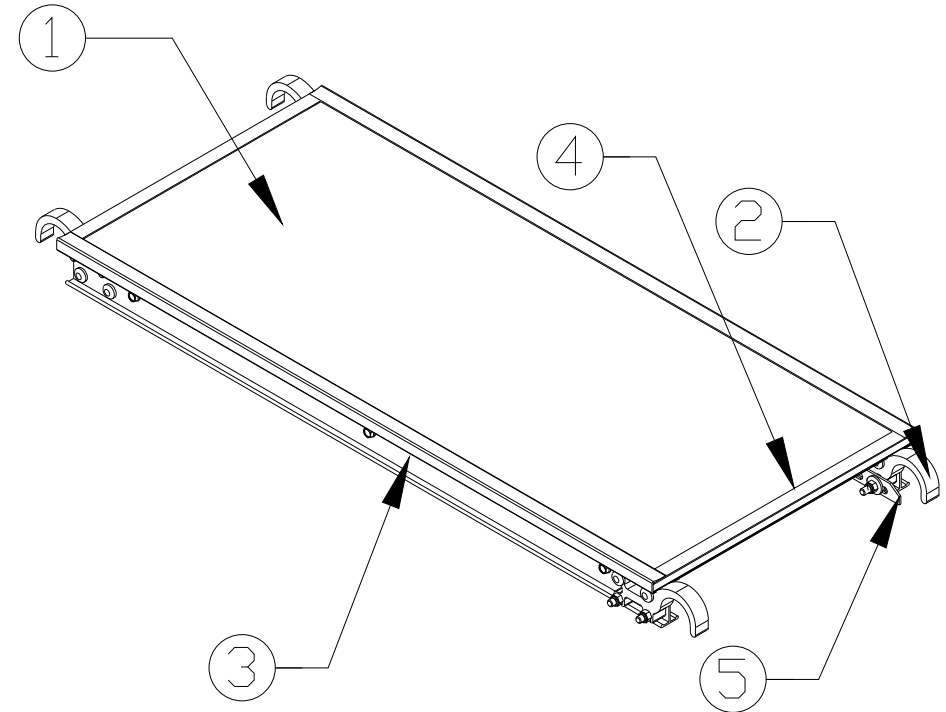
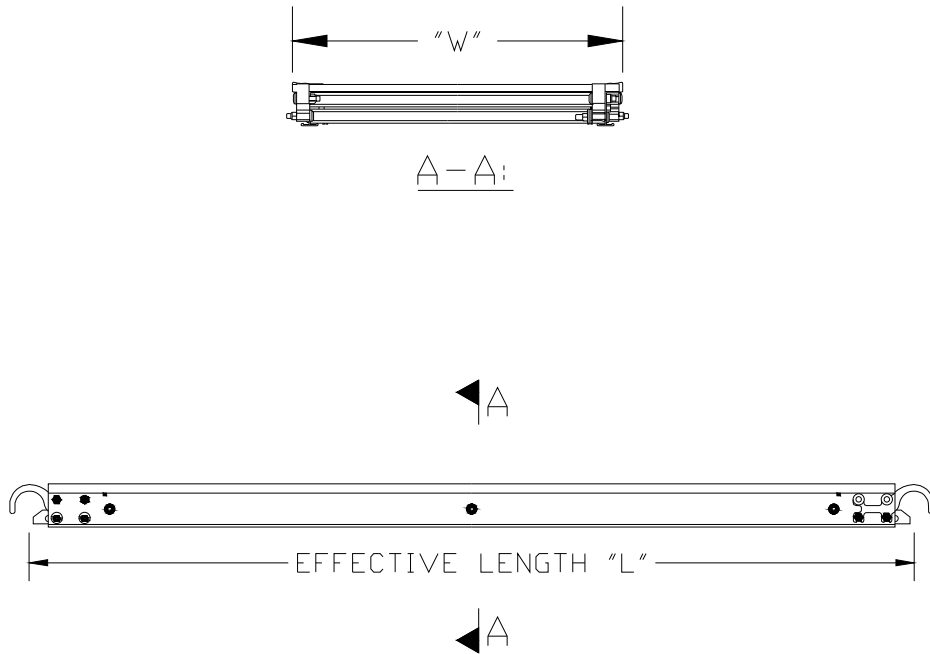

ULTRA LITE™ CFRT DECK DIAGRAM

NOTES:

1. ABOVE DIAGRAM DOES NOT DEPICT THE EXACT DIMENSIONS OF ALL CFRT DECKS
2. ALL ALTERNATIVE UNITS SHOWN ARE MILLIMETRES
3. FOR ALLOWABLE LOADING CONTACT NSP

TRACEABILITY CODE:

NSPMMYYXXXX

- REFERENCE NUMBER
- YEAR CODE
- MONTH CODE
- NORTH SCAFFOLD PRODUCTS LTD.

ITEM NO.	LENGTH "L"	WIDTH "W"	WEIGHT	COMPONENTS	
03CD0311T	3'-10" [910]	1'-7" [483]	5.9kgs/12.9lbs	S.NO.	DESCRIPTION
03CD0312T	3'-10" [910]	2'-0" [610]	6.5kgs/14.4lbs	1	CFRT
03CD0519T	5'-0" [1524]	1'-7" [483]	7.9kgs/17.5lbs	2	LEDGER HOOK
03CD0520T	5'-0" [1524]	2'-0" [610]	8.8kgs/19.4lbs	3	ALUM. BEAM
03CD0521T	5'-2" [1572]	1'-7" [483]	8.2kgs/18.1lbs	4	END CAPS
03CD0522T	5'-2" [1572]	2'-0" [610]	9.2kgs/20.2lbs	5	WIND LATCH
03CD0701T	7'-0" [2130]	1'-7" [483]	11.7kgs/25.7lbs		
03CD0702T	7'-0" [2130]	2'-0" [610]	13.1kgs/28.8lbs		
03CD1001T	10'-0" [3050]	1'-7" [483]	17.9kgs/39.5lbs		
03CD1002T	10'-0" [3050]	2'-0" [610]	20.1kgs/44.4lbs		