

Swivel Wedge Clamp

TOP
PROFILE:

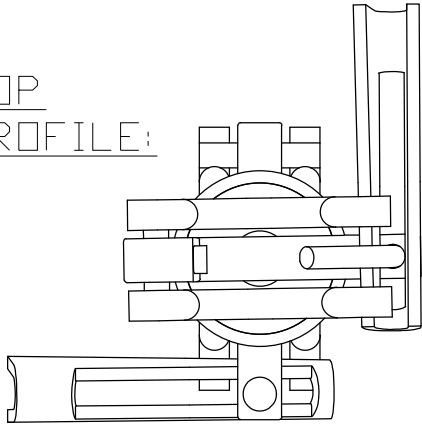

SIDE
PROFILE:

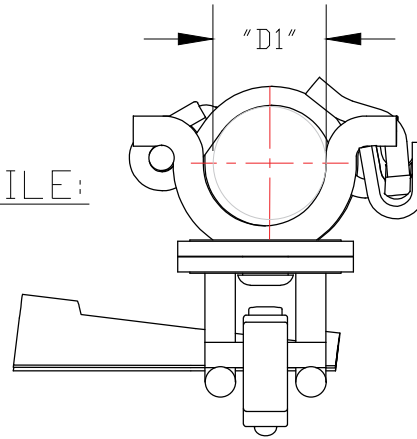

FRONT
PROFILE:

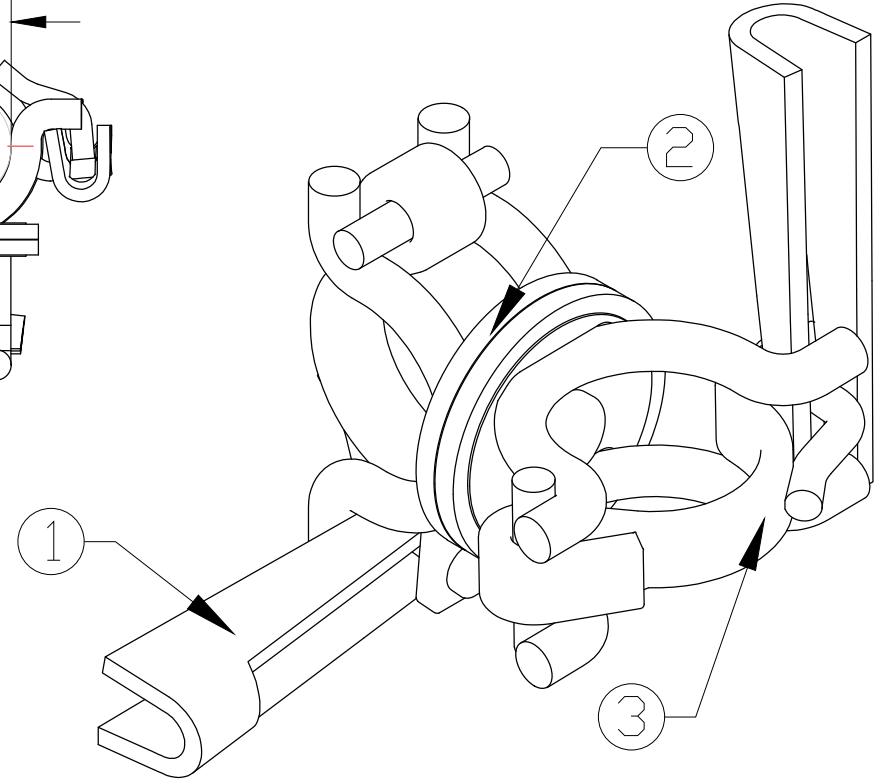
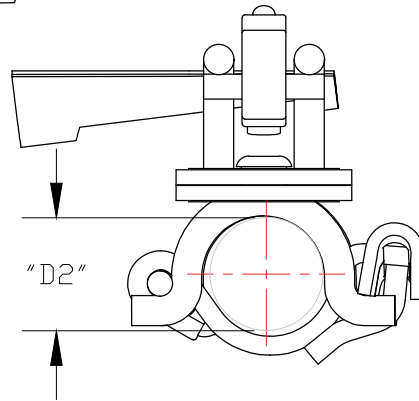

SWIVEL WEDGE CLAMP DIAGRAM

NOTES:

1. ABOVE DIAGRAM DOES NOT DEPICT THE EXACT LAYOUT OF ALL SWIVEL WEDGE CLAMPS
2. D1 AND D2 REPRESENT THE TUBE DIAMETERS TO BE USED WITH THE CORRESPONDING SWIVEL WEDGE CLAMP
3. ALL ALT. UNITS ARE MILLIMETERS

ITEM NO.	"D1" x "D2"	WEIGHT	COMPONENTS	
05SW4843G	48mm x 43mm	1.66kgs/3.65lbs	S.NO.	DESCRIPTION
05SW4848G	48mm x 48mm	1.68kgs/3.70lbs	1	WEDGE
			2	SWIVEL
			3	WIRE CLAMP