

Right Angle Wedge Clamp

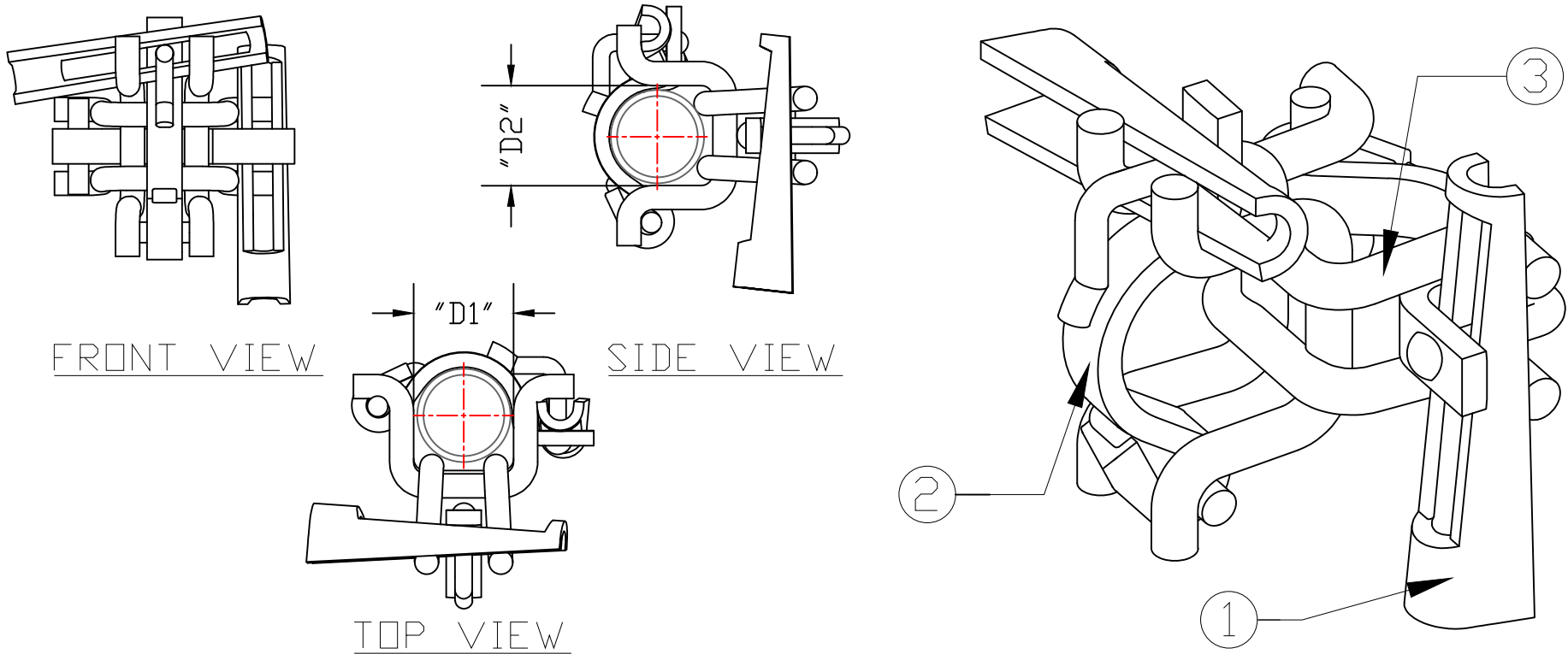

RIGHT ANGLE WEDGE CLAMP DIAGRAM

NOTES:

1. THE WEDGE CLAMP USES THE FRICTION CREATED BY THE WEDGE TO CREATE A TIGHT & SECURE FIT CONNECTING TWO TUBES AT A 90° ANGLE
2. ALL ALT. UNITS ARE MILLIMETERS

ITEM NO.	D1 x D2	WEIGHT	SYSTEM	COMPONENTS	
RA4843	48 x 43 mm	1.4kgs/3.1lbs	ALL	S.NO.	DESCRIPTION
RA4848	48 x 48 mm	1.4kgs/3.1lbs	ALL	1	WEDGE
				2	WIRE CLAMP
				3	WIRE